

# PMDC Motor

## 60 Watt

Frame Size: □ 90 mm

Replaceable Carbon Brush Permanent Magnet Motor.  
Rotates in Clockwise or Counter Clockwise Direction.  
Continuous Rating, Lead Wires for Connection.



### Specifications:

Mode	Supply Voltage	Current A	Rated Torque N.m	Rated Speed RPM
90 PT 4□ 60	12 V	6.0	0.42	1350
90 PU 4□ 60	24 V	3.0	0.42	1350
90 PW 4□ 60	90 V	0.8	0.42	1350
90 PX 4□ 60	180 V	0.4	0.42	1350

□ Type Of Shaft, G for Gear Shaft, R for Round Shaft

### Gearmotor Torque Table:

The maximum permissible torque is 20 N.m

Unit : N.m

RPM	500	416	300	250	200	166	120	100	83	60	50	41	30	25	20	16	15	12.5	10	8.3
Gear Ratio	3	3.6	5	6	7.5	9	12.5	15	18	25	30	36	50	60	75	90	100	120	150	180
Output Torque	1.0	1.2	1.7	2.0	2.5	3.1	3.8	4.6	5.5	6.8	8.2	9.8	12.4	14.9	18.6	20.0	20.0	20.0	20.0	20.0

The Gear boxes are sold separately.

A coloured background indicates gear shaft rotation in same direction as motor shaft.

A white background indicates gear shaft rotation in opposite direction to the motor shaft.

The speed of geared motor is calculated by dividing motor's standard speed by the gear ratio.

The actual speed is 2 - 20% less than the displayed value, depending upon the load.

Characteristics, specifications and dimensions are subject to change without notice.

## Dimensions

### Motor with Gear Box

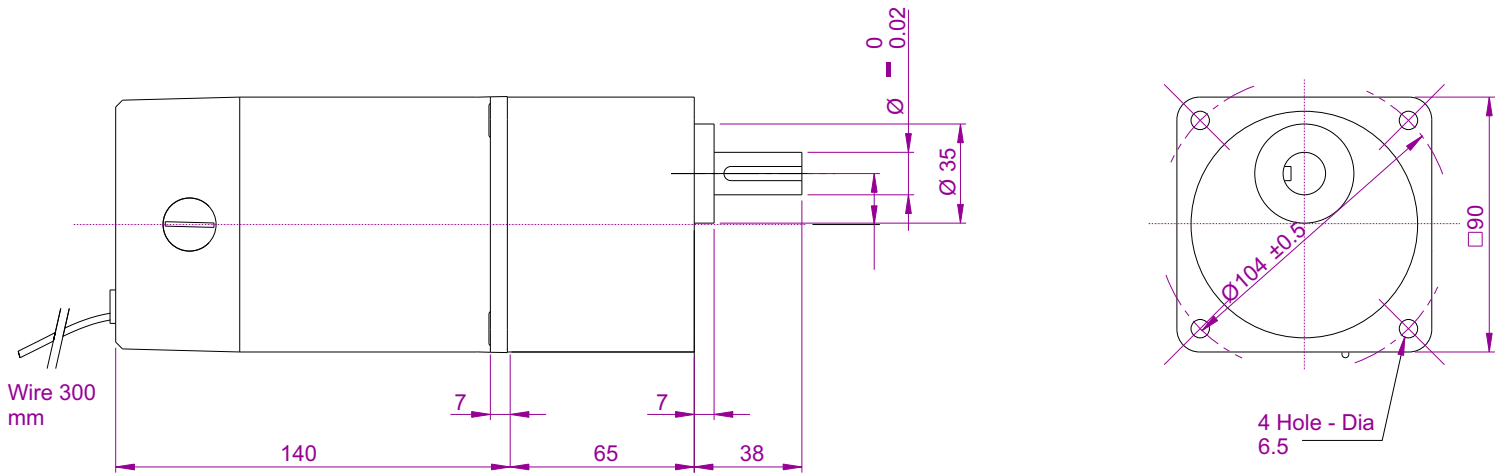

### Motor Round Shaft

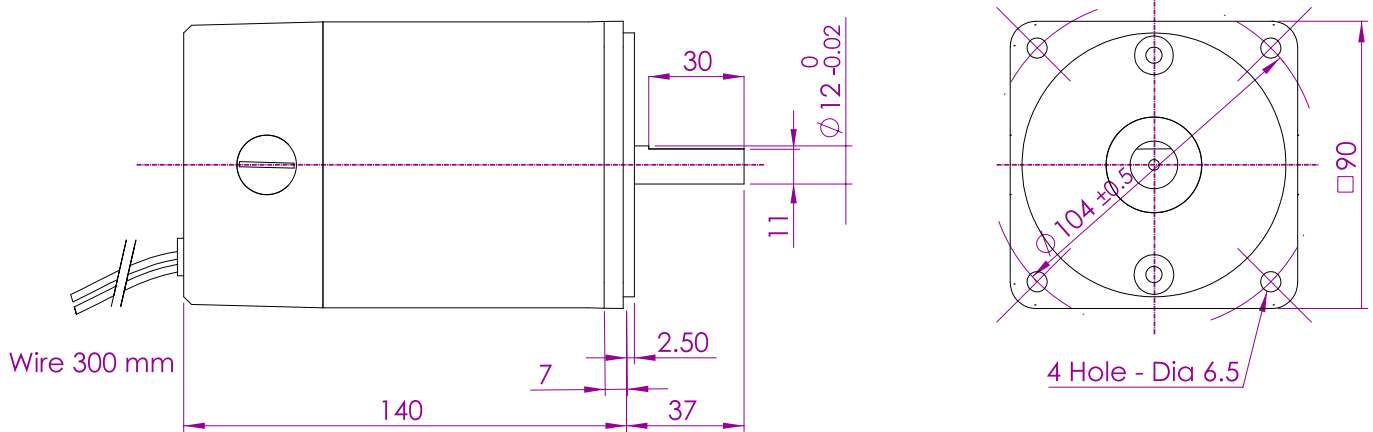

## Key & Keyway

